

Turbomolecular Drag Pumps

With Electronic Drive Units TC 100



TMH 071 P

TMU 071 P

	Page		Page
1. Safety Instructions	3	5. Monitoring Operations	15
1.1. For Your Orientation.....	3	5.1. Operations Display Via LED.....	15
1.2. Pictogram Definitions.....	3	5.2. Turbopump Temperature Management.....	15
2. Understanding The Pumps		6. What To Do In Case Of	
TMH 071 P/TMU 071 P	4	Breakdowns ?	16
2.1. Main Features.....	4	7. Maintenance	17
Proper Use	4	7.1. Replacing The Lubricant Reservoir.....	17
Improper Use	4	8. Service	18
2.2. Differences Between The Pump Types.....	4	9. Technical Data	19
3. Installation	5	9.1. Dimensions Diagram	20
3.1. Preparations For Installation.....	5	10. Spare Parts	21
3.2. Installing The Pump,		11. Accessories.....	22
Connecting The High Vacuum Side	5	Declaration of Contamination.....	23
Fitting The Splinter Shield (Accessory).....	6	Manufacturer's Declaration	(last page)
3.3. Connecting The Fore-Vacuum Side	6		
3.4. Connecting The Cooling Unit.....	7		
3.5. Connecting The Venting Valve.....	7		
3.6. Connecting The Casing Heating Unit.....	7		
3.7. Connecting The Electronic Drive Unit TC 100.....	8		
3.8. Installing The Power Unit	8		
3.9. Installing The Operating And Display			
Control Unit DCU 001/DCU 100	8		
3.10. Connecting The Sealing Gas Valve	8		
3.11. Remote Control Unit.....	9		
3.12. Connecting The Serial Interface RS 485	10		
Connection	10		
Connecting The RS 485	10		
3.13. Connections Diagram	11		
4. Operations	12		
4.1. Before Switching ON.....	12		
4.2. Switching ON.....	12		
4.3. Operations Via The Remote Control Unit	12		
Local/Remote	12		
Accessory Inputs	12		
Pumping Station	12		
Standby/Reset	12		
Switch Outputs	13		
Accessory Outputs	13		
Analog Output.....	13		
4.4. Gas Type Dependent Operations	13		
4.5. Switching OFF And Venting.....	14		
4.6. Operations With The DCU 001/DCU 100	14		
4.7. Shutting Down For Longer Periods	14		

Please note: Current operating instructions are available via www.pfeiffer-vacuum.de under "Infoservice".

1. Safety Instructions

- ☞ Read and follow all instructions in this manual.
- ☞ Inform yourself regarding:
 - Hazards which can be caused by the pump;
 - Hazards which can be caused by your system.
 - Hazards which can be caused by the media being pumped.
- ☞ Avoid exposing any part of the body to vacuum.
- ☞ Observe the safety and accident prevention regulations.
- ☞ Regularly check that all accident prevention measures are being complied with.
- ☞ Do not operate the turbopump with open high vacuum flange.
- ☞ Do not carry out any unauthorised conversions or alterations to the turbopump with TC 100.
- ☞ When returning the turbopump observe the shipping instructions.
- ☞ Use at least 4 bracket screws to connect the high vacuum flange (ISO-flange).
- ☞ The turbopump must be anchored in accordance with the installation instructions.
- ☞ Do not disconnect the plug between the TC 100 and accessory components during operations.
- ☞ Disconnect the voltage supply for the TC 100 before opening the turbopump.
- ☞ When working on the turbopump, the high vacuum flange should only be opened once the rotor is at rest.
- ☞ When using sealing gas, the pressure in the hose connection should be limited to 2 bar via the overpressure valve.
- ☞ If a heater is in use temperatures of up to 120 °C can be present in the area of the high vacuum flange. Take care to avoid burns !
- ☞ During operations, temperatures of up to 65 °C can arise in the lower part of the turbopump. Take care to avoid burns!
- ☞ Keep leads and cables well away from hot surfaces (> 70 °C).
- ☞ Operate the turbopump with TC 100 only in conjunction with the relevant power unit (accessory).
- ☞ The unit has been accredited protection class IP 30. When the unit is operated in environments which require other protection classes, the necessary measures must be taken. Protection class IP54 is afforded for the Electronic Drive Unit TC 100 by using a suitable 15 pole D-Sub plug (accessory).
- ☞ The mains connection must be subject to a safe connection to the PE (protection class 1).

1.1. For Your Orientation

Instruction in the text

- ➔ Working instruction: here, you have to do something.

Abbreviations used

- DCU = Display and operating unit
- TC = Electronic drive unit, turbopump
- TMP = Turbomolecular pump
- TPS = Power unit
- TCS = Connection Box

Symbols used

The following symbols are used throughout in all illustrations.

- ⊕ High vacuum flange
- ⊖ Fore-vacuum flange
- ⊞ Venting connection
- ⊗ Cooling water connection
- ⊕ Air cooling
- ⚡ Electric connection
- ⊙ Sealing gas connection

Position numbers

The same pump and accessory parts have the same position numbers in all illustrations.

1.2. Pictogram Definitions



Warning, danger of burns from touching hot parts.



Warning, danger of personal injury.



Caution, danger of damage to the pump or to the system.



Warning, danger of injury from rotating parts.



Please note, attention to particularly important information on the product, handling the product or to a particular part of the documentation.

Modifications reserved.

2. Understanding The Pumps TMH 071 P/TMU 071 P

2.1. Main Features

Turbopumps TMH 071 P/TMU 071 P with the TC 100 form a complete unit. Voltage is supplied by the power unit (see "Accessories").



Cooling

- Enhanced convection cooling with cooling unit (accessory),
- air cooling (accessory) or
- water cooling (accessory).

Integrated protective measures against excess temperatures:

The Electronic Drive Unit TC 100 reduces the rotor rotation speed.

Bearings

High vacuum side: Wear free permanent magnetic bearing.

Fore-vacuum side: Oil circulatory lubricated ball bearing with ceramic balls.

Proper Use

- The Turbomolecular Pumps TMH 071 P/TMU 071 P may only be used for the purpose of generating vacuum.
- The turbopumps may only be used to pump those media against which they are chemically resistant. For other media the operator is required to qualify the pumps for the processes involved.
- If the process produces dust, the maintenance intervals must be specified accordingly and sealing gas must be used.
- The turbopump must be connected to a backing pump in accordance with Section 3.3.
- Only Pfeiffer Vacuum power units may be used to operate. The use of other power units requires the prior agreement of the manufacturer and equalization with the valid specification.
- The pumps with TC 100 may only be operated providing the ambient conditions in compliance with Protection Type IP 30 are observed.

Improper Use

The following is regarded, inter alia, as improper:

- The pumping of explosive or corrosive gases.
- Operating the pumps in areas where there is a danger of explosion.
- The pumping of gases and vapours which attack the materials of the pumps.
- The pumping of corrosive gases without sealing gas.
- The pumping of condensating vapours.
- Operations involving impermissibly high levels of gas loads.
- Operations with improper gas modes.
- Operations involving too high levels of heat radiation power (see Section 9. "Technical Data").
- Operating the pump in environments which require a protection class superior to IP 30.
- Operations without the use of cooling equipment.
- The use of other power units or accessories which are not named in this manual or which have not been agreed by the manufacturer.

Improper use will cause all claims for liability and guarantees to be forfeited.

2.2. Differences Between The Pump Types

Feature	TMH 071 P	TMU 071 P
High vacuum flange	ISO-KF / ISO-K	CF-F
High vacuum seal	Elastomer	Metal
Attainable final pressure	$< 1 \cdot 10^{-7}$ mbar (without baking-out)	$< 5 \cdot 10^{-10}$ mbar (with baking-out)

Abbreviations on the type of the pump

Suffix "P": Purge gas connection for the prevention of the ingress of aggressive gases into the motor and bearing arena.

3. Installation

3.1. Preparations For Installation



Do not carry out any unauthorised conversions or alterations to the turbopump. The operator must ensure that the TC 100 is integrated into an emergency safety circuit. The supply voltage of the TC 100 must be interrupted when releasing the emergency safety condition. For special requirements please contact Pfeiffer Vacuum.

- The option to connect two of accessory components is provided on the Connection Box TCS 010 (please see "Accessories") which is secured into the Electronic Drive Unit TC 100.

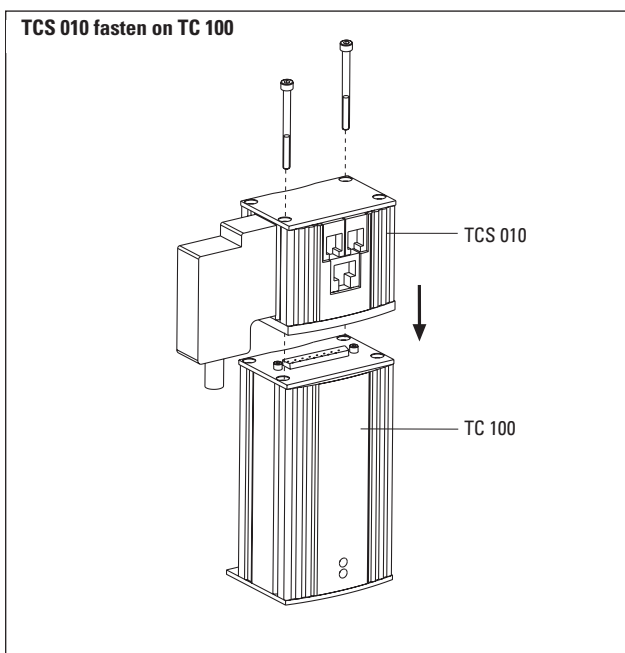

- The maximum permissible rotor temperature of the pump is 80 °C. If the vacuum chamber is heated or if parts in the vacuum chamber are operated at high temperature, the heat production in the pump may not exceed the values indicated in the technical data. If necessary, suitable shielding should be installed in the vacuum chamber in front of the turbopump (constructional suggestions available on request).
- The temperature of the high vacuum flange may not exceed 120 °C.
- Only remove the blank flange from the high and fore-vacuum side immediately before connection.
- On Turbopumps TMH 071 P/TMU 071 P the lubricant reservoir is already fitted and filled.
- Where magnetic fields of > 3 mT are involved suitable shielding must be provided (available on request).
- If the pump is baked out, the heating sleeve and the body of the pump must be insulated to prevent burns from accidental contact.

- In the event of a sudden standstill of the rotor, torques of up to 330 Nm can arise and these must be taken up by the turbopump and frame. Pumps must be anchored as follows:
 - ISO flange with 4 bracket screws, or
 - CF flange with the complete set of M8 screws, or
 - Underside of the pump with 4 screws M5, screws quality 8.8.
- Either air or water cooling is necessary for operating the pump. Where operations with convection cooling are involved, a cooling unit must be used (please see "Accessories")

3.2. Installing The Pump, Connecting The High Vacuum Side



The utmost cleanliness must be observed when fitting all high vacuum parts. Unclean components prolong the pumping time.

Using the splinter shield

The use of a splinter shield in the high vacuum flange protects the turbopump against foreign bodies coming from the vacuum chamber but does reduce the volume flow rate of the pump by approximately 15%. For fitting splinter shields please refer to "Fitting the splinter shield"

The high vacuum side can be flanged directly to the vacuum chamber or via a bellows or a Pfeiffer Vacuum vibration compensator.

Connecting via a bellows

If the high vacuum side is to be flanged via a bellows, the turbopump must be secured for example via the holes on the underside of the turbopump must be secured for example via the holes on the underside of the pump. The fastening must be able to withstand the torque referred to in Section 3.1.

Connecting via a Pfeiffer Vacuum vibration compensator (accessory)



The maximum permissible temperature at the vibration compensator is 100 °C.

Where a Pfeiffer Vacuum vibration compensator is in use, a freely suspended turbopump can be flanged onto the vacuum chamber. Additional fastening is unnecessary.

Directly flanging the pump

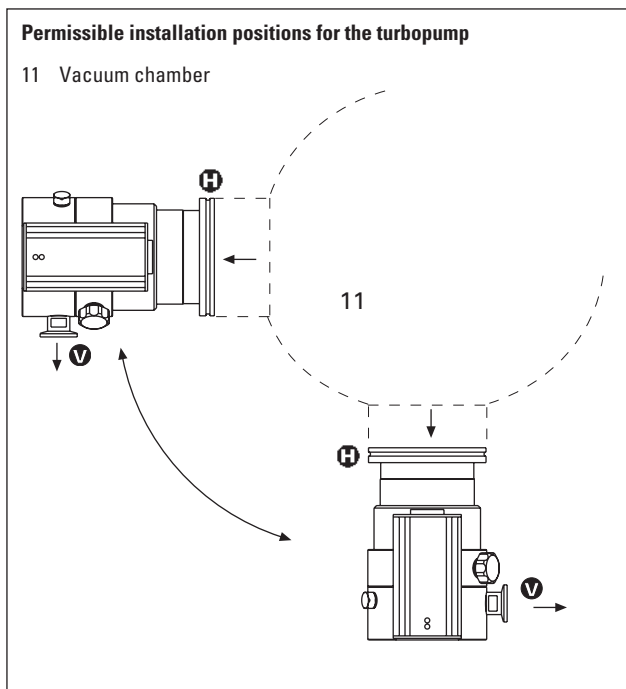

The maximum loading capacity of the high vacuum flange is 200 N (equivalent to 20 kg). Assymmetric loading on the high vacuum flange must be avoided.

With horizontal pump installation and oil-sealed backing pumps (e.g. rotary vane pumps) the fore-vacuum flange of the turbopump must be aligned vertically downwards (maximum deviation $\pm 20^\circ$), otherwise the turbopump could become dirty.

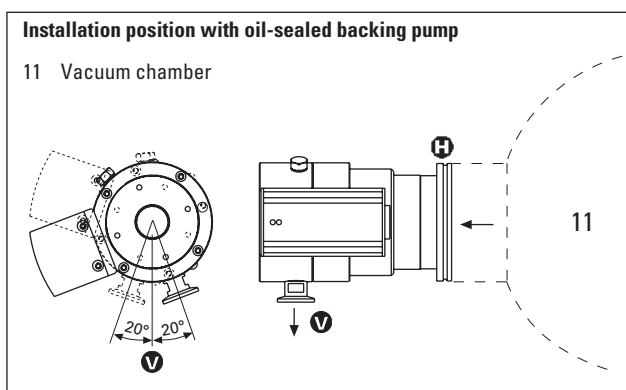

No forces from the piping system must be allowed to act on the pump where turbopumps are anchored. Suspend or support all pipes to the pump.

Fitting The Splinter Shield (Accessory)

Insert the splinter shield in the high vacuum flange in such a way that the corrugation of the strainer points outwards.

DN 63

- ➔ Bend the clamping lugs slightly outwards so that subsequently the splinter shield is seated firmly in the high vacuum flange (to avoid noise).
- ➔ Insert the splinter shield in the high vacuum flange while pressing the clamping lugs slightly inwards.
- ➔ Press the outer ring of the splinter shield up to the limit stop point in the high vacuum flange.

DN 40

- ➔ Insert the splinter shield up to the limit stop point in the high vacuum flange (bend not the clamping lugs outwards).

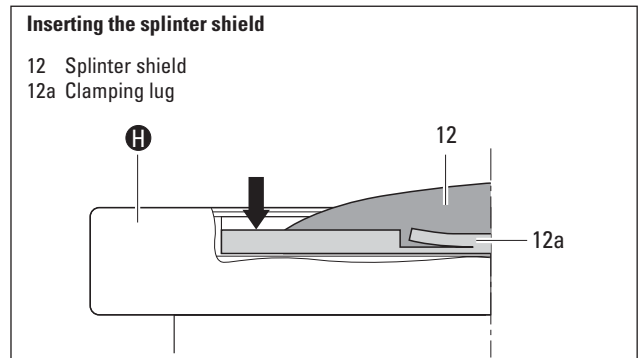

3.3. Connecting The Fore-Vacuum Side

- Backing pump: Vacuum pressure ≤ 10 mbar; with enhanced convection cooling $< 0,1$ mbar.
- Recommendation: Oil-Free Diaphragm Pump or Rotary Vane Vacuum Pumps from the Pfeiffer Vacuum range (note installation position, turbopump, see Section 3.2.).

Connecting the backing pump

All connections of the fore-vacuum line: with the usual small flange components or hose screw connections.



Be sure to conduct away the exhaust gases from the backing pump. Do not reduce the free cross section of the fore-vacuum flange with following components.



The exhausted process gases and vapours can represent a health hazard and can also be environmentally damaging. Comply with all the gas manufacture's safety instructions.

- ➔ With rigid pipe connections: fit a bellows in the connecting line to reduce vibration.
- ➔ The fore-vacuum pump is controlled via a relay box (accessory) and Connection Box TCS 010 (accessory) or in accordance with the connections diagram (please refer to Section 3.13.).

Please refer to Operating Instructions PT 0030 BN for details on the relay box, backing pump and its installation and to Operating Instructions PT 0045 BN for details on the Connection Box TCS 010.

3.4. Connecting The Cooling Unit

Turbopumps TMH 071 P/TMU 071 P can optionally be provided with enhanced convection cooling, air cooling or water cooling.

The turbopumps must be operated with air or water cooling where the fore-vacuum pressure is increased (> 0.1 mbar) and/or operations with gas loads.

Use and installation

- For water cooling please refer to Operating Instructions PM 800 546 BN.
- Permissible installation positions for the cooling unit where convection cooling is involved please see Section 9.1. "Dimensions Diagram".
- For air cooling please refer to Operating Instructions PM 800 543 BN.
The electrical connection for the air cooling is effected via the control lead in the connection "Out1" of the TCS 010 or in accordance with the connections diagram (please see Section 3.13.).

3.5. Connecting The Venting Valve

The venting valve (accessory) provides automatic venting in the event of a power failure and switching off.

Fitting the venting valve

- ➔ Unscrew the venting screw from the venting connection of the turbopump.
- ➔ Screw in venting valve with seal (USIT ring) on hexagonal SW 14.

Electrical connection

- ➔ Plug control lead into the connection "Out2" of the TCS 010 or in accordance with the connections diagram (please see Section 3.13.).

For Details please refer to Operating Instructions for the Connection Box TCS 010, PT 0045 BN.

The venting mode of the venting valve is selected via the DCU or Serial Interface RS 485.



The maximum pressure at the venting valve is 1.5 bar absolute.

Please refer to Operating Instructions PM 800 507 BN for details on Venting Valve TVF 005.

3.6. Connecting The Casing Heating Unit

In order to accelerate attainment of final pressures, turbopumps and vacuum chambers can be heated.

Baking out is only practical on pumps with stainless steel casings (TMU pumps). On account of their aluminium casings, the temperatures attainable on TMH pumps are not high enough.

Heating duration is dependent on the level of contamination and the required final pressure but should be at least four hours.



Where casing heating is involved the turbopump must be water cooled.



High temperatures are generated when turbopumps are heated.

There is a danger of injury from coming into contact with hot parts even after the casing heating has been switched off.

Heating sleeve and the pump casing should be thermally insulated during the installation. During the heating phase be careful not to come into contact with the heating sleeve or the pump casing.

Casing heating control is effected via the TCS 010 (please refer to Operating Instructions PT 0045 BN for the TCS 010) or in accordance with the connections diagram (please see Section 3.13.).

For details regarding the casing heating and its installation please refer to Operating Instructions PM 800 542 BN.

3.7. Connecting The Electronic Drive Unit TC 100



The turbopump and the Electronic Drive Unit TC 100 are connected and together form a single unit. Connecting cable 8a has to be ordered separately (for cable with bridge please see "Accessories").

Connecting without DCU

- ➔ Connect plug X3 on connecting cable 8a with connection X3 on the TC 100 and secure with screw 8b.
- ➔ Connect plug X2 on connecting cable 8a with Power Unit TPS 100 ("Accessories") on connection X2 (please refer to Section 3.13. Connection Diagram).



Once operations voltage has been supplied, the Electronic Drive Unit TC 100 performs a self test on the supply voltage. The supply voltage for Turbomolecular Pumps TMH/TMU 071 P is 24 VDC $\pm 5\%$ in accordance.

(Connecting with DCU 001/DCU 100 please refer to Operating Instructions PM 800 477 BN.)

3.8. Installing The Power Unit



Voltage may only be supplied with the Pfeiffer Vacuum power units (Accessory). The use of other power units requires the prior agreement of the manufacturer and equalization with the valid specification (power unit specifications available on request).

For further details regarding Power Unit TPS 100 please refer to Operating Instructions PM 800 521 BN.

3.9. Installing Operating And Display Control Unit DCU 001/DCU 100

The connection of an Operating And Display Control Unit DCU 001/DCU 100 is available with a TCS 010 (accessory) or a connecting cable TC 100/DCU - TPS (accessory). Please refer to the permissible operating instructions and Section 3.13. Connection Diagram.

3.10. Connecting The Sealing Gas Valve

To protect the turbopump, especially where corrosive and dusty processes are involved, it is necessary to use sealing gas. Connection is effected via the sealing gas valve (please refer to "Accessories").

For the sealing gas connection please refer to Section 9.1. Dimensions.

For further details regarding the installation of the sealing gas valve and setting the sealing gas level please refer to Operating Instructions PM 800 229 BN.

Connecting the Electronic Drive Unit TC 100 with Power Unit TPS 100

- X1 Mains connection
- X2 Connection, power unit
- X3 Connection TC 100
- S1 ON/OFF switch
- 8 Electronic Drive Unit TC 100
- 8a Connecting cable, TC 100 – TPS 100
- 8b Screw
- 105 Power Unit TPS 100

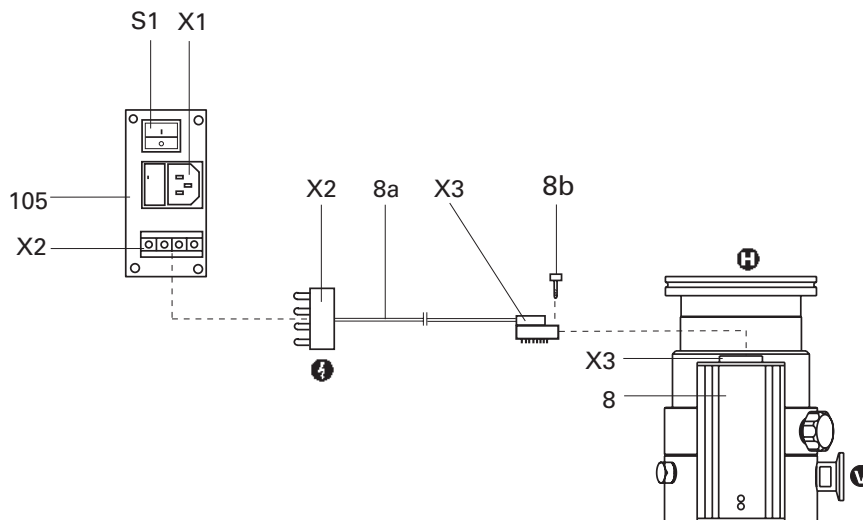

3.11. Remote Control Unit

Remote control options for various functions are available via connection plug X3 (Pin 2 – Pin 6) on the TC 100.

Shielded cable must be used. The shielding on the plug side of the Electronic Drive Unit TC 100 should be connected to the metal cap on the plug.

Inputs 2-6 are activated by supplying +24 VDC* from Pin 7 (active high) (please refer to Section 3.13. Connections Diagram).

Pin arrangement and functions of the 15 pole plug X3 (please refer to the following table)

Pin Arrangement And Functions Of Plug X3			
Pin nr.	Function		
1	Supply voltage	+24 VDC ±5% ($I_{dauer} = 4,2 \text{ A}$; $I_{max} = 4,6 \text{ A}$)	
	Inputs:	Open (low)	Closed (high)
2	Input remote/local ¹⁾	Remote: priority of Serial Interface RS 485	Local: priority of inputs (Pin 3-6)
3	Input accessory 1	not vent or heating OFF	vent or heating ON
4	Input accessory 2		
5	Input pumping station	Pumping station OFF	Pumping station ON: turbopump, backing pump and fan are switched ON
6	Input standby/reset	Standby OFF	Standby ON: Pump is accelerated to 66% of the nominal rotation speed. Reset: By supplying a pulse ($T < 2 \text{ s}$) with an amplitude of 24 V a malfunction acknowledgement can be processed.
7	+ 24 VDC*		
	Outputs:	low (0 V)	high (24 V)
8	Switch output 1	Rotation speed switchpoint not attained	Rotation speed switchpoint attained: Output can be loaded with 24V/50mA
9	Switch output 2	Collective error message	trouble free operating: Output can be loaded with 24V/50mA
10	Accessory output 1	Accessory OFF	Accessory ON Works setting: fan
11	Accessory output 2	Accessory OFF	Accessory ON Works setting: automatic venting
12	Analog output	0 - 10 VDC = 0 - 100% * f_{end} (optional current/power)	
13	Serial Interface RS 485	D + (DO/RI)	
14	Serial Interface RS 485	D - (DO/RI)	
15	Mass (ground)		

1) Only possible with activated parameter 028.
No function on delivery.

3.12. Connecting The Serial Interface RS 485

The connection of the Operating And Control Unit DCU 001/DCU 100 is possible via the TCS 010 (accessory) or cable TPS - TC 100/DCU (accessory), please refer to Operating Instructions for the TCS 010, PT 800 045 BN and the Operating Instructions for the DCU 001/100, PN 800 477 BN.

Pin	Arrangement
1	not connected
2	+ 24 V output (loadable with 210 mA)
3	not connected
4	not connected
5	RS 485: D+ (DO / RI)
6	Gnd — —
7	RS 485: D- (DO / RI)
8	not connected

RS 485

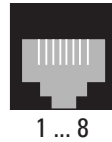

View from the TCS 010 plug side)

An external computer can be connected directly to Serial Interface RS 485 via connection X3 (Pin 13, Pin 14).

Connection

Designation	Value
Pin 13: D+	
Pin 14: D-	
Serial interface type:	RS 485
Baud rate:	9600 Baud
Data file word length:	8 bit
Parity:	no parity
Start bits:	1
Stop bits:	1..2



It is possible to connect an RS 232 (e.g. PC) via a level converter (please see "Accessories").

Connecting The RS 485

Connection to a fixed bus system

- ➔ Connect all units with D+ (Pin 13/X3) and D- (Pin 14/X3) on the bus.
- ➔ The bus must be closed at both ends.

The connections must be made in accordance with the Serial Interface RS 485 specifications.

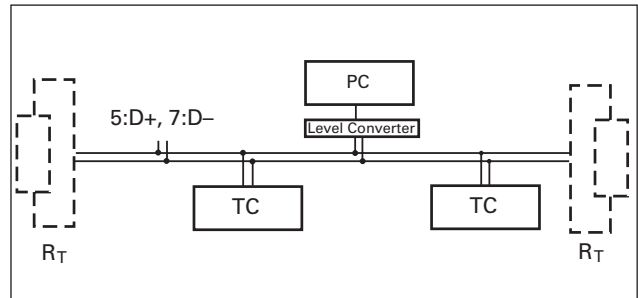

All units connected to the bus must have differing serial interface addresses (parameter 797).

The group address of the Electronic Drive Unit TC 100 is 950.



Only safety low voltage may be connected to the Serial Interface RS 485.

All switched on remote control functions have priority over the serial interface functions.



For further details regarding the operation of the Serial Interface RS 485 and its electrical data please refer to separate Operating Instructions PM 800 488 BN.

Profibus DP Gateway TIC 250 is available (accessory) for connecting an Electronic Drive Unit TC 600 to a Profibus DP. Please refer to the respective Operating Instructions PM 800 599 BN for detailed information on the operation of the TIC 250.

3.13. Connections Diagram

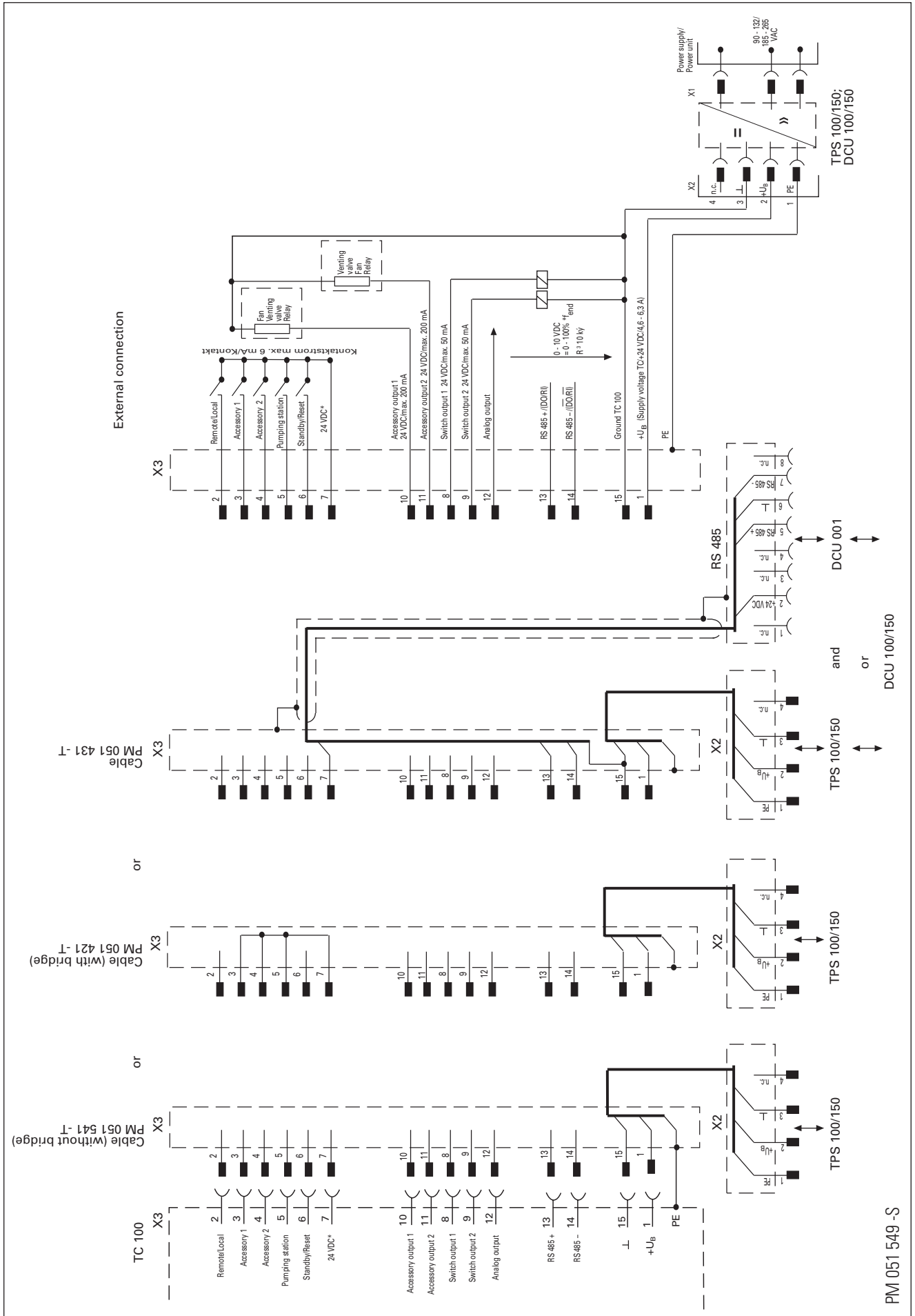

PM 051 549 -S

4. Operations

4.1. Before Switching ON



Turbopump rotors turn at great speed. When the high vacuum flange is open there is a danger of personal injury and of damage to the pump resulting from the falling in of objects. Therefore, never operate the pump with an open high vacuum flange.

- ➔ With water cooling: open cooling water supply and check flow.
- ➔ Plug connecting cable 8a ("Accessory") into the TC 100 and connect with Power Unit TPS 100 (please see Section 3.7.).

Please note:

The following works settings are programmed:

– Start-up time:	8 min
– Rotation speed switchpoint	80%
– Automatic venting	50%

For further works settings please refer to the parameter overview in the operating instructions for the "Pumping Operations With the DCU", PM 800 547 BN.

These settings can only be altered via Serial Interface RS 485 (DCU or PC) (please refer to the respective operating instructions).



Take care when pumping hazardous gases. Take note of all safety recommendations of the gas manufacturer.

4.2. Switching ON

- ➔ Switch on the power unit with S1.
- After successful completion of the self-test on the TC 100 (duration approximately 10 seconds), the turbopump is ready to operate.

The turbopump is operated via remote control (please refer to Section 4.3.).

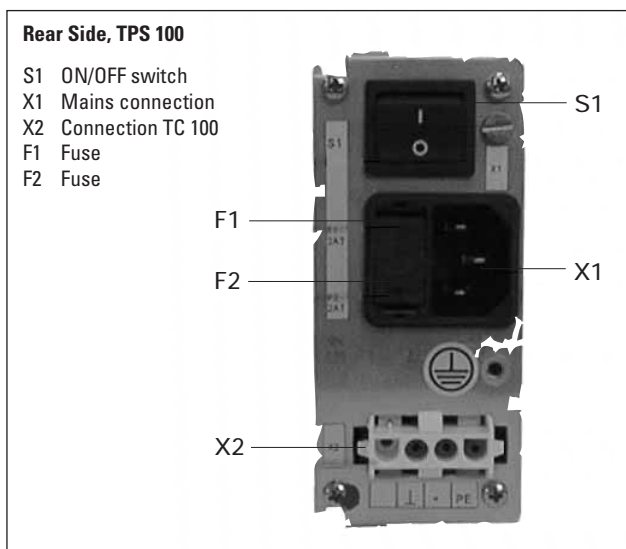

4.3. Operations Via The Remote Control Unit

(Please refer to the table in Section 3.11. and connection diagram in Section 3.13.)

Remote control options are possible via inputs Pin 2 – Pin 6/X3 on the TC 100.

Shielded cable must be used. The shielding on the plug side of the Electronic Drive Unit TC 100 should be connected to the metal cap on the plug.

Inputs 2 - 6 are activated when they are connected to 24 VDC* on Pin 7/X3 (active high).

Local/Remote

(Pin 2/X3)

This input is used to determine whether the control should be effected via remote control inputs or Serial Interface RS 485 (**only works in conjunction with parameter 028, please refer to Operating Instructions for Pumping Operations with the DCU, PM 800 547 BN).**

Accessory Inputs

(Pin 3/X3 and Pin 4/X3)

The components backing pump and air cooling (connectable to the accessory outputs) are switched automatically. The remote control inputs Pin 3 and Pin 4 are then ineffective. If the outputs are programmed to venting valve or the heating there is the option with the respective inputs venting release after the unit has been switched off and heating ON/OFF when the rotation speed switchpoint is exceeded.

Works setting: Out1 (Pin 3) = air cooling
Out2 (Pin 4) = venting valve

The accessory inputs and outputs can be assigned several functions via a DCU or the Serial Interface RS 485.

Pumping Station

(Pin 5/X3)

Connected pumping station components are started (backing pump, air cooling) and the turbopump is set in motion after successful completion of the self-test (duration approximately 10 seconds).

Standby/Reset

(Pin 6/X3)

With the use of "standby" the turbopump can be operated optionally at 66% of the nominal rotation speed (standby ON) or with the nominal rotation speed (standby OFF). By supplying a pulse ($T < 2s$) with an amplitude of 24 V a malfunction acknowledgement can be processed.

Switch Outputs

(Pin 8/X3 And Pin 9/X3)

The switch outputs 1 and 2 can be loaded with maximum 24V/50 mA per output. The following functions are assigned to the switch outputs:

Switch output 1: Active high after attainment of the rotation speed switchpoint. The switchpoint for the turbopump is set at 80% of the nominal rotation speed. It can be used, for example, for a signal "Pumpe betriebsbereit" ("pump ready to operate").

Switch output 2: Active low on collective error signal.

The connection of a relay is made between Pin 15 (mass) and the respective switch output Pin 8 or Pin 9 (please refer to Section 3.13. Connections Diagram).

Accessory Outputs

(10/X3 and Pin 11/X3)

The accessory outputs can be loaded with a maximum of 24 V/200 mA.

The works setting on the accessory outputs are:

Accessory output 1:

A connected air cooling system is started.

Accessory output 2:

A connected venting valve is started if venting release has been transmitted via accessory input 2.

Additional components can also be connected by respective selection via the DCU or the RS 485.

Analog Output

(Pin 12/X3)

A rotation speed proportional voltage (0 - 10 VDC correspond to 0 - 100%* f_{end}) can be tapped via the analog output (load $\geq 10\text{ k}\Omega$).

Additional functions (power, current) can be assigned to the analog output via a DCU or Serial Interface RS 485.

4.4. Gas Type Dependent Operations



Water cooling is required if the pumps are to be operated with gas load.

Where high level gas loads and rotation speeds are involved, the resulting friction subjects the rotor to the effect of great heat. To avoid over-heating, a power rotation speed characteristic line is implemented in the TC 100; this ensures that where maximum gas loads are involved, the pump will operate at any rotation speed without the danger of damage arising.

The maximum power is dependent on the type of gas. Two characteristic lines are available for any type of gas in order to fully exploit the power potential of the pump:

- "Gas-Mode 0" for gases with molecular mass ≥ 40 as, for example, Argon;
- "Gas-Mode 1" for all lighter gases.

➔ Set the applicable gas mode on the TC 100 via the DCU 001 or DCU 100 (please refer to Operating Instructions "Pumping operations with The DCU" PM 800 547 BN). Works setting: Gas mode 0



Pumping gases with molecular mass ≥ 40 with the incorrect gas mode can cause damage to the pump.

For the vertex of the power characteristic line please refer to Section 9. Technical Data.

Maximum power is applied when the pump starts in order to limit the time required. Once the set rotation speed is attained, switching to the selected power characteristic line is automatic.

If the gas dependent maximum power is exceeded, the rotation speed is reduced until equilibrium between the permissible power and gas friction is attained. The power limitation serves to protect the pump against thermal overloading. In order to avoid rotation speed fluctuations it is recommended to set, in rotation speed setting mode, the equilibrium frequency or a somewhat lower frequency.



There can be types of pump whereby there is no differentiation between the two "gas modes" settings.

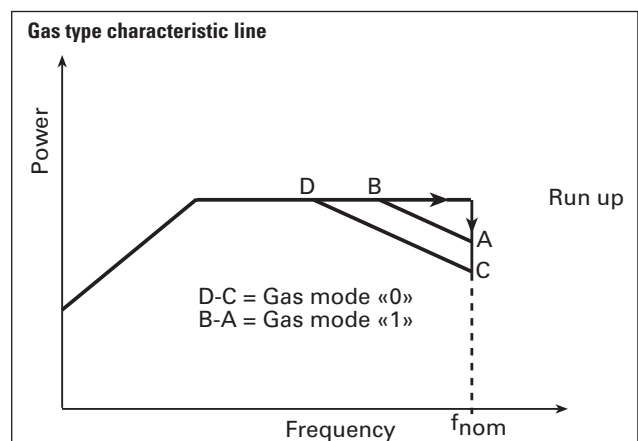

4.5. Switching OFF And Venting

Before coming to rest after switching off, the turbopump must be vented in order to prevent contamination.

- ➔ Close the fore-vacuum.
- ➔ Switch off the turbopump with switch S1 on the power unit.
- ➔ Venting

There are three possibilities to vent turbopump:

- **Manual venting**
Open the venting screw (on delivery, screwed in) on the venting connection about one turn.
- **Venting with the Venting Valve TVF 005** (accessories)
Venting release via the remote control (please see Section 4.3.) or via the serial interface which is selectable via DCU or interface (see Operating Instructions, "Pumping Operations With The DCU", PM 800 547 BN).
- **Venting in two stages** when the vacuum chamber should be vented as quickly as possible.
First stage: venting with a pressure increase rate of 15 mbar/s for 20 seconds.
Second stage: venting with an optionally large venting valve.

The valve cross-section for a venting rate of 15 mbar/s must be compatible with the size of the vacuum chamber. Where small vacuum chambers are involved, the PFEIFFER Venting Valve TVF 005 can be used for first stage venting.

- ➔ Shut off water supply (if installed).

4.6. Operations With The DCU 001/DCU 100

Operations with the DCU 001 or DCU 100 should be carried out in accordance with the relevant Operating Instructions PM 800 477 BN (DCU description) and PM 800 547 BN (operating the pump with the DCU).

4.7. Shutting Down For Longer Periods



If aggressive or hazardous gases are pumped there is a danger of personal injury resulting from coming into contact with process gases. Before removing a turbopump from the system, first:

- Vent the turbopump with a neutral gas or dry air.
- Ensure that there is no residual process gas in the system nor in the feeder lines.

If the turbopump is to be shut down for more than a year:

- ➔ Remove turbopump from the system.
- ➔ Change the lubricant reservoir (see Section 7.1.)



Lubricant TL 011 should not be used when there have been no operations for **2 years**.

- ➔ Close the high vacuum flange and evacuate the turbopump via the fore-vacuum flange.
- ➔ Vent turbopump via the venting connection with nitrogen or dry air.
- ➔ Close fore-vacuum and venting connection by blank flanging.
- ➔ Place the pump vertically on its rubber feet.
- ➔ In rooms with moist or aggressive atmospheres, the turbopump must be air-sealed in a plastic bag together with a bag of dessicant, e.g. silicagel.



If the pump has been shut down for **3 years**, the bearing must be changed (please contact Pfeiffer Vacuum Service).

5. Monitoring Operations

5.1. Operations Display Via LED

Certain operations modes of the turbopump and the TC 100 can be ascertained via the two integrated LEDs located on the front panel of the Electronic Drive Unit TC 100.

The following operations modes are displayed:

LED		Cause
green	red	
Glows		<ul style="list-style-type: none"> – Power unit OK – Function "pumping station ON" carried out
Flashes		<ul style="list-style-type: none"> – Power unit OK – Pumping station OFF
Blinks		<ul style="list-style-type: none"> – Mains power supply failure
	Glows	<ul style="list-style-type: none"> – Collective malfunction (for example, run-up time error, over-temperature, turbopump or TC 100) – Switching output 2 active (low)
	Blinks	<ul style="list-style-type: none"> – Warning (e.g. supply voltage short circuit to earth, mains power failure)



Differentiated malfunction and warning signals are only possible with the use of the DCU.

5.2. Turbopump Temperature Management

Where impermissible motor temperatures are involved or the temperature of the casing is too high, the motor current is reduced.

This can lead to dipping below the set rotation speed switch-point and results in the turbomolecular pump being switched off.

LED on the TC 100 glows red: Collective malfunction.

6. What To Do In Case Of Breakdowns?

Problem	Possible Causes	Remedy
Pump doesn't start; None of the integrated LEDs glow on the TC 100	<ul style="list-style-type: none"> • Power supply interrupted • Incorrect operations voltage supplied • Pins 3,4,5 and 7 on the Plug X3 not connected • No supply of operations voltage • Defect TC 100 • Reduction in the voltage in the cable 	<ul style="list-style-type: none"> • Check fuse in the power unit • Check plug contacts on the mains power unit • Check power unit feeder line • Check voltage on the power unit (24 VDC) at connection X2 • Supply correct operations voltage • Connect pins 3,4,5 and 7 on the plug X3 • Check plug contacts on the power unit • Inform Pfeiffer Vacuum Service of need for repair • Use suitable cable
Pump doesn't attain nominal rotation speed within the set run-up time Pump cuts out during operations	<ul style="list-style-type: none"> • Fore-vacuum pressure too high • Leak or too much gas • Rotor sluggish caused by defective bearing • TC run-up time too short • Thermal overloading caused by <ul style="list-style-type: none"> – Water flow insufficient – Insufficient air supply – Fore-vacuum pressure too high – Ambient temperature too high 	<ul style="list-style-type: none"> • Check backing pump function • Check seals • Seek leak and repair • Reduce supply of process gas • Check bearing (noises?): Inform Pfeiffer Vacuum Service • Set longer start-up time with the DCU or RS 485 • Ensure free flow • Ensure adequate air supply • Reduce fore-vacuum pressure • Reduce ambient temperature
Pump doesn't attain final pressure	<ul style="list-style-type: none"> • Pump dirty • Leak in vacuum chamber, lines or pump 	<ul style="list-style-type: none"> • Bake out pump • If seriously contaminated: Request Pfeiffer Vacuum Service to clean • Seek leak starting with vacuum chamber • Repair leak
Unusual operating noises	<ul style="list-style-type: none"> • Bearing damaged • Rotor damaged • Splinter shield (if fitted) not seated firmly 	<ul style="list-style-type: none"> • Inform Pfeiffer Vacuum Service of need for repair • Inform Pfeiffer Vacuum Service of need for repair • Check seat of splinter shield (see Section 3.2.)
Red LED on the TC 100 glows	<ul style="list-style-type: none"> • Collective malfunction 	<ul style="list-style-type: none"> • Reset via mains OFF/ON when the TMP is at standstill or remote pin 6 • Different malfunction display with the DCU possible¹⁾
Red LED on the TC 100 flashes	<ul style="list-style-type: none"> • Warning through: <ul style="list-style-type: none"> – Mains power failure – Supply voltage short circuit to earth 	<ul style="list-style-type: none"> • Different warning message with the DCU possible¹⁾ • Check power unit voltage • Check power unit mains connection • Check power unit voltage for short circuit earth

1) Without a DCU inform Pfeiffer Vacuum Service to check the cause of trouble.

7. Maintenance



No liability for personal injury nor material damage will be accepted for damages and operational interruptions which have been caused by improper maintenance; in addition, all guarantees become invalid.

- You can change the lubricant reservoir yourself (please see Section 7.1.).
- Your pump can be cleaned on the spot if it is not very dirty. Your local Pfeiffer Vacuum Service can advise you regarding cleaning procedures and any other maintenance and service work.



Apply no mechanical stress to the TC 100.

7.1. Replacing The Lubricant Reservoir

The lubricant reservoir should be replaced at least once a year.

Where extreme operating conditions or unclean processes are involved, the replacement interval should be checked with your Pfeiffer Vacuum Service Center.

- ➔ Switch off the turbopump, vent to atmospheric pressure (see Section 4.5.) and allow to cool as necessary.
- ➔ If necessary, remove the turbopump from the system.
- ➔ Unscrew rubber feet 6 from the underside of the pump.
- ➔ Remove the locking cover 90 on the underside of the pump with adjustable pin type face wrench E (order number N 5709 103); take care with the O-ring 91.
- ➔ Lever out the lubricant reservoir 92 with the help of two screwdrivers.

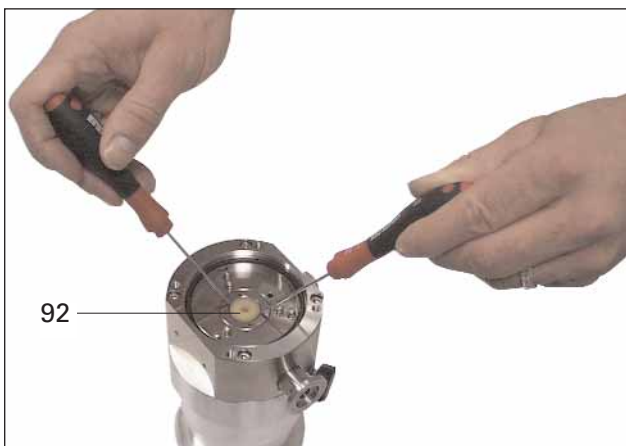

The Lubricant reservoir can contain toxic substances from the medium pumped. Lubricant must be disposed of in accordance with the respective regulations.

Safety instructions data sheet for the lubricant on request.

Remove locking cover and extract lubricant reservoir

- 1 High vacuum flange
- 6 Rubber feet (4x)
- 90 Locking cover
- 91 O-ring
- 92 Lubricant reservoir
- 93 O-ring
- E Adjustable pin type face wrench

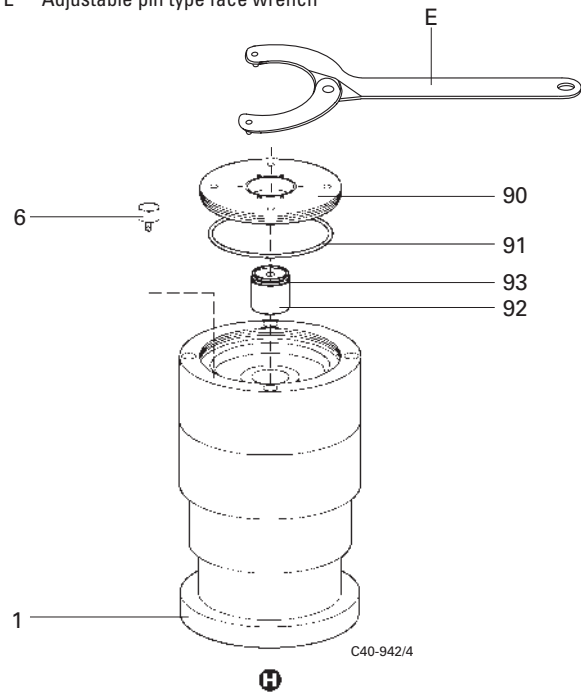

- ➔ Clean off any dirt on the pump and locking cover with a clean, fluff-free cloth.
- ➔ Insert new lubricant reservoir 92 up to the O-ring 93 in the pump.



The lubricant reservoir 92 is already filled with Lubricant TL 011; do not add additional lubricant.

- ➔ Screw in locking cover 90 with O-ring 91. The lubricant reservoir is brought into the correct axial position with the locking cover.
- ➔ Screw the rubber feet 6 back in.

8. Service

Do make use of our service facilities

In the event that repairs are necessary a number of options are available to you to ensure any system down time is kept to a minimum:

- Have the pump repaired on the spot by our Pfeiffer Vacuum Service Engineers;
- Return the pump to the manufacturer for repairs;
- Replace the pump.

Local Pfeiffer Vacuum representatives can provide full details.



Please take into account that where Pfeiffer Vacuum Service replacement service is involved the standard operating parameters are always pre-set.

If your application requires different parameters, please modify accordingly.



The turbopump and the Electronic Drive Unit TC 100 form a single unit and must therefore be returned complete for repair purposes. Before returning the unit it should be ensured that the power unit is not the cause of the malfunction (checking the power unit).

Before returning:

- ➔ If the unit is free of harmful substances, please attach a clearly visible notice "Free of harmful substances" (both on the unit and also on the delivery note and any accompanying letters).

"Harmful substances" are substances and preparations as defined in the current, local, dangerous substances regulations; in the U.S.A. as

"materials in accordance with the Code of Federal Regulations (CFR) 49 Part 173.240 Definition and Preparation". We will carry out the decontamination and invoice this work to you if you have not attached this note. This also applies where the operator does not have the facilities to carry out the decontamination work. Units which are contaminated microbiologically, explosively or radioactively cannot be accepted as a matter of principle.

Fill out the declaration of contamination

- ➔ In every case the "Declaration of Contamination" must be completed diligently and truthfully.
- ➔ A copy of the completed declaration must accompany the unit; any additional copies must be sent to your local Pfeiffer Vacuum Service Center.

Please get in touch with your local Pfeiffer Vacuum representatives if there are any questions regarding contamination.



Decontaminate units before returning or possible disposal. Do not return any units which are microbiologically, explosively or radioactively contaminated.

Returning contaminated units

If contaminated have to be returned for maintenance/repair, the following instructions concerning shipping must be followed:

- ➔ Neutralise the pump by flushing with nitrogen or dry air.
- ➔ Seal all openings to the air.
- ➔ Seal pump or unit in suitable protective foil.
- ➔ Ship units only in appropriate transport containers.



Repair orders are carried out according to our general conditions of sale and supply. If repairs are necessary, please send the pump to your nearest Pfeiffer Vacuum Service Center.

Contact addresses and telephone hotline

Contact addresses and telephone numbers can be found on the back cover of these operating instructions.

9. Technical Data

Feature	Unit	TMH 071 P	TMH 071 P	TMU 071 P
Connection nominal diameter				
Inlet		DN 40 ISO-KF	DN 63 ISO-K	DN 63 CF-F
Outlet		DN 16 ISO-KF/G 1/4"	DN 16 ISO-KF/G 1/4"	DN 16 ISO-KF/G 1/4"
Venting connection		G 1/8"	G 1/8"	G 1/8"
Nominal rotation speed	1/min	90 000	90 000	90 000
Standby rotation speed	1/min	60 000	60 000	60 000
Start-up time	min	2	2	2
Noise level	dB (A)	< 45	< 45	< 45
Final pressure, backing pump	mbar	< 10	< 10	< 10
Maximum permissible rotor temperature	°C	80	80	80
Permissible heat radiation power	W	4	4	4
Volume flow rate for				
Nitrogen N ₂	l/s	33	60	60
Helium He	l/s	38	55	55
Hydrogen H ₂	l/s	39	45	45
Compression ratio for				
N ₂		> 10 ¹¹	> 10 ¹¹	> 10 ¹¹
He		1 · 10 ⁷	1 · 10 ⁷	1 · 10 ⁷
H ₂		> 10 ⁵	> 10 ⁵	> 10 ⁵
Maximum fore-vacuum pressure for				
N ₂	mbar	18	18	18
He	mbar	17	17	17
H ₂	mbar	8	8	8
Maximum gas throughput ¹⁾				
With water cooling				
N ₂	mbar l/s	1.1	1.1	1.1
He	mbar l/s	2.5	2.5	2.5
With air cooling ²⁾				
N ₂	mbar l/s	0.45	0.45	0.45
Maximum gas throughput at intake pressure of 0.1 mbar ³⁾				
With water cooling				
N ₂	mbar l/s	2.2	2.2	2.2
He	mbar l/s	2.6	2.6	2.6
H ₂	mbar l/s	2	2	2
Vertex power characteristics line ⁴⁾				
A	W / Hz	80 / 1500	80 / 1500	80 / 1500
B	W / Hz	80 / 1500	80 / 1500	80 / 1500
C	W / Hz	55 / 1500	55 / 1500	55 / 1500
D	W / Hz	80 / 1300	80 / 1300	80 / 1300
Final pressure ⁵⁾				
With rotary vane pumps	mbar	< 1 · 10 ⁻⁷	< 1 · 10 ⁻⁷	< 5 · 10 ⁻¹⁰
With diaphragm pumps	mbar	< 1 · 10 ⁻⁷	< 1 · 10 ⁻⁷	< 1 · 10 ⁻⁸
Lubricant		TL 011	TL 011	TL 011
Maximum cooling water consumption with water at 15 °C ⁶⁾	l/h	100	100	100
Cooling water temperature	°C	5 - 25	5 - 25	5 - 25
Permissible ambient temperature with air cooling	°C	0 - 35	0 - 35	0 - 35
Heating power consumption	W	32	32	32
Weight	kg	3.2	3.2	4.2
Permissible magnetic field	mT	3	3	3
Operating voltage	VDC	24 ± 5%	24 ± 5%	24 ± 5%
Duration ⁶⁾ - / max. current consumption	A	4.1 / 4.6	4.1 / 4.6	4.1 / 4.6
Duration ⁶⁾ - / max. power	W	100 / 110	100 / 110	100 / 110
Fuse, internal	V	T8A/250	T8A/250	T8A/250
Protection class ⁷⁾		IP 30	IP 30	IP 30
Relative humidity	%	5-85 non-condensing	5-85 non-condensing	5-85 non-condensing

1) Until frequency fall-off; higher gas throughputs with reduced rotation speed.

2) Until ambient temperature 30 °C.

3) Rotation speed of pump may drop below the nominal rotation speed.

4) For gas type characteristic lines please refer to section 4.5.

5) In accordance with German Industrial Standard 28428 the final pressure which is attained in a measuring dome 48 hours after baking out.

6) At maximum gas throughput.

7) Protection class IP 54 on request

9.1. Dimensions Diagram

TMH 071 P / TMU 071 P

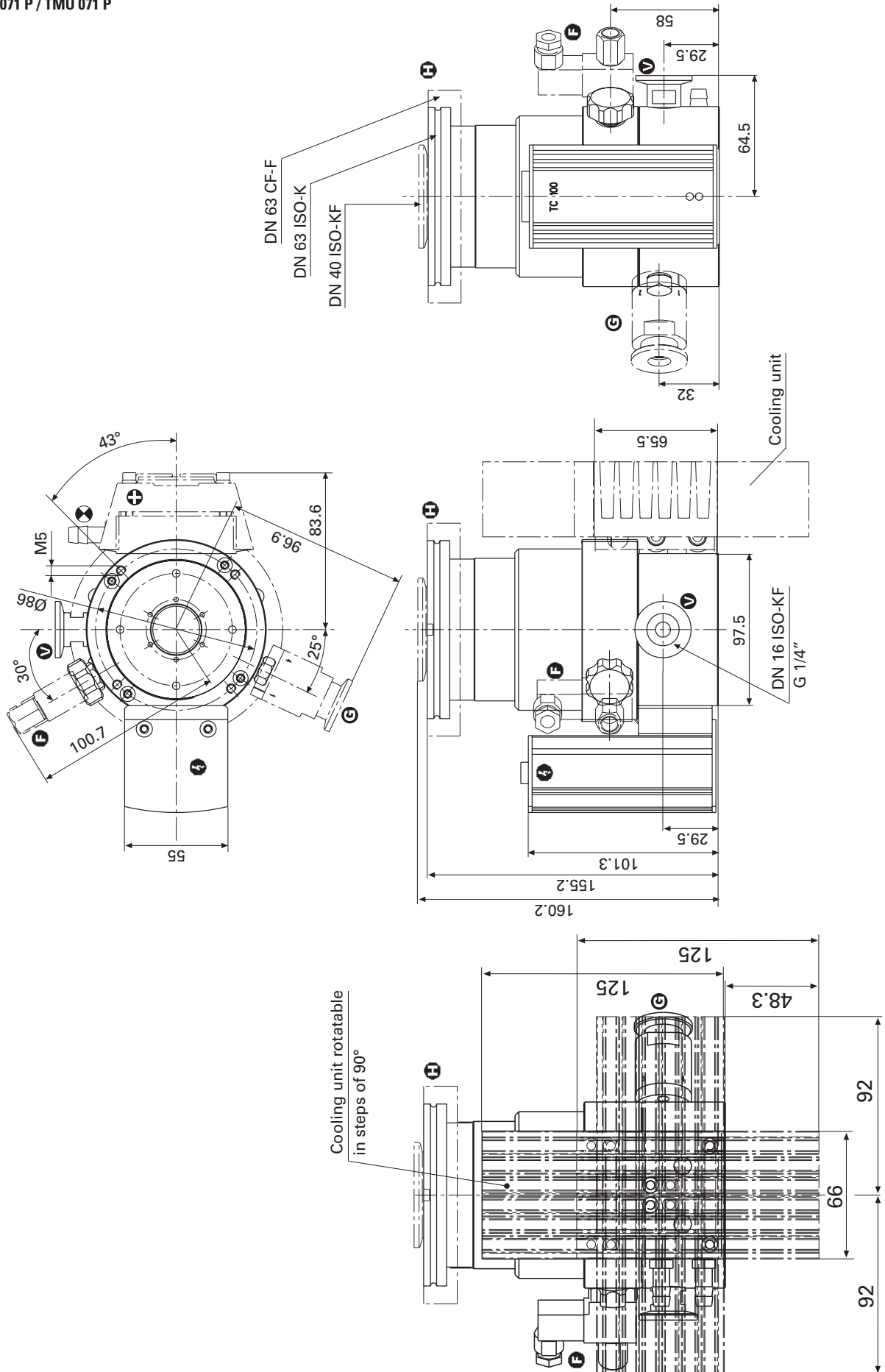

10. Spare Parts

Pos.	Description	Pieces	Size	Number	Comments	Ordering Quantity
	Spare Parts TMH/TMU 071 P					
	Set of seals	1		PM 083 077 -T		
17	USIT ring	1		P 3529 133 -A		
90	Locking cover	1		PM 083 021 -X		
91	O-ring	1	68x3	P 4070 972 PP		
92	Lubricant reservoir (with O-ring 93)	1		PM 073 073 -T		

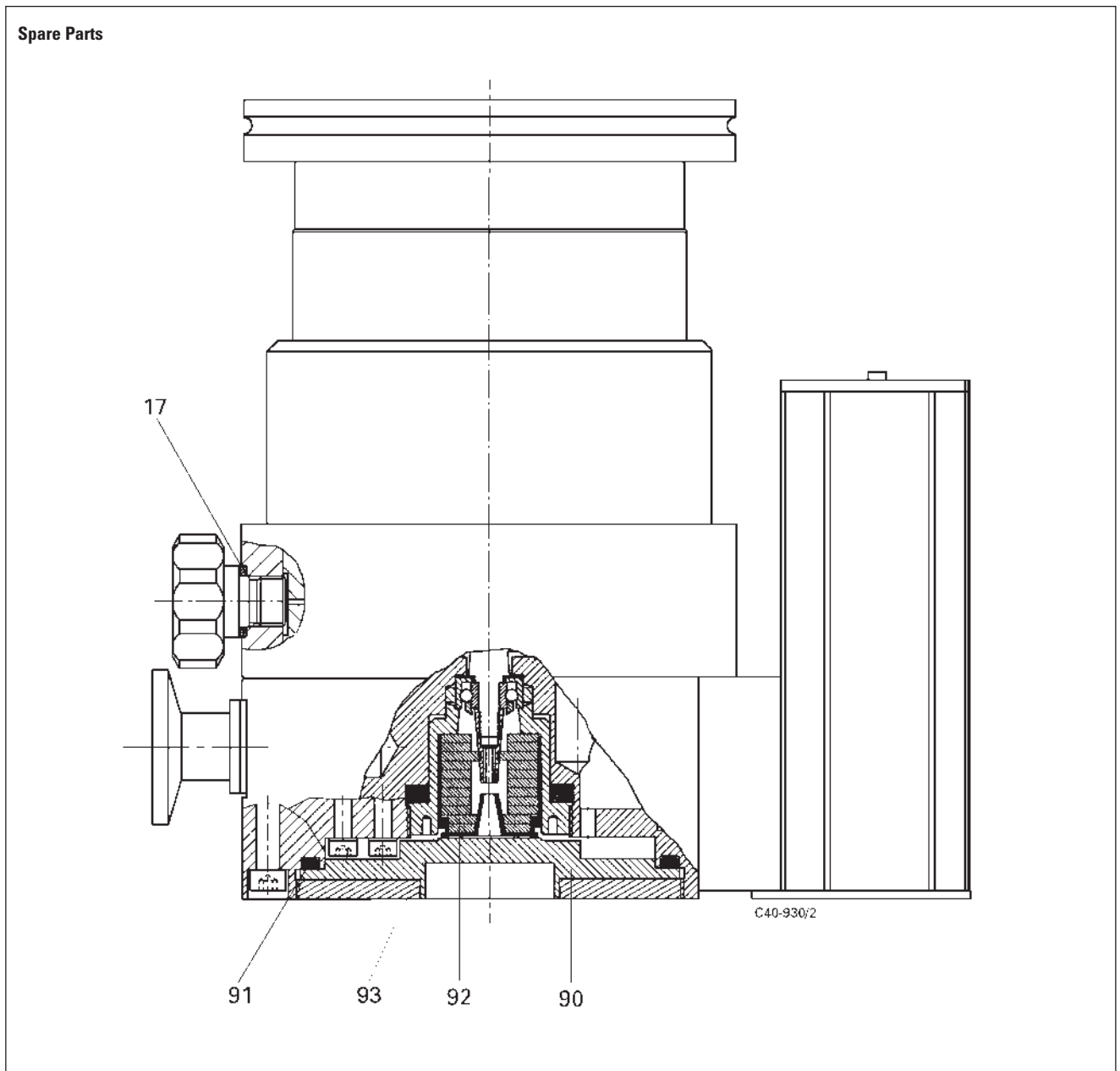

Declaration of Contamination of Vacuum Equipment and Components

The repair and/or service of vacuum components will only be carried out if a correctly completed declaration has been submitted. Non-completion will result in delay.

The manufacturer could refuse to accept any equipment without a declaration.

This declaration can only be completed and signed by authorised and qualified staff:

1. Description of component:

- Equipment type/model: _____
- Code No.: _____
- Serial No.: _____
- Invoice No.: _____
- Delivery Date: _____

2. Reason for return:

3. Equipment condition

- Has the equipment been used?
yes no
- What type of pump oil was used?

- Is the equipment free from potentially harmful substances?
yes (go to section 5)
no (go to section 4)

4. Process related contamination
of equipment

- toxic yes no
- corrosive yes no
- microbiological hazard*) yes no
- explosive*) yes no
- radioactive*) yes no
- other harmful substances yes no

*) We will not accept delivery of any equipment that has been radioactively or microbiologically contaminated without written evidence of decontamination!

Please list all substances, gases and by-products which may have come into contact with the equipment:

Tradename Product name Manufacturer	Chemical name (or Symbol)	Danger class	Precautions associated with substance	Action if spillage or human contact
1.				
2.				
3.				
4.				
5.				

5. Legally Binding Declaration

I hereby declare that the information supplied on this form is complete and accurate. The despatch of equipment will be in accordance with the appropriate regulations covering Packaging, Transportation and Labelling of Dangerous Substances.

Name of Organisation: _____

Address: _____ Post code: _____

Tel.: _____

Fax: _____ Telex: _____

Name: _____

Job title: _____

Date: _____ Company stamp: _____

Legally binding signature: _____

Herstellererklärung Manufacturer's Declaration

im Sinne folgender EU-Richtlinien:
pursuant to the following EU directives:

- **Maschinen/Machinery 98/37/EWG (Anhang/Annex II B)**
- **Elektromagnetische Verträglichkeit/Electromagnetic Compatibility 89/336/EWG**
- **Niederspannung/Low Voltage 73/23/EWG**

Hiermit erklären wir, daß das unten aufgeführte Produkt zum Einbau in eine Maschine bestimmt ist und daß deren Inbetriebnahme so lange untersagt ist, bis festgestellt wurde, daß das Endprodukt den Bestimmungen der EU-Richtlinie 98/37/EWG entspricht.

Das unten aufgeführte Produkt entspricht den Anforderungen der EU-Richtlinien **Maschinen 98/37EWG, Elektromagnetische Verträglichkeit 89/336/EWG** und **Niederspannung 73/23/EWG**.

We hereby certify that the product specified below is intended for installation in a machine which is forbidden to be put into operation until such time as it has been determined that the end product is in accordance with the provision of EU Directive 98/37/EEC.

*The product specified below is in correspondence to the EU directives **Machinery 98/37/EEC, Electromagnetic Compatibility 89/336/EEC** and **EU Low Voltage 73/23/EEC**.*

Produkt/Product:

TMH 071 P mit/with TC 100
TMU 071 P mit/with TC 100

Angewendete Richtlinien, harmonisierte Normen und angewendete nationale Normen:

Guidelines, harmonised standards, national standards in which have been applied:

EN 292-1, EN 292-2, EN 294
EN 1012-2, EN 61010

Unterschrift/Signature:



Pfeiffer Vacuum GmbH
Berliner Str. 43
35614 Asslar
Germany

(W. Dondorf)
Geschäftsführer
Managing Director

Your Vacuum Technology Experts in



Turbo Pumps



Rotary Vane Vacuum Pumps



Roots Pumps



Dry Vacuum Pumps



Leak Test Units



Valves



Flanges, Feedthroughs



Vacuum Measurement



Gas Analysis



System Technology



Service

PFEIFFER  **VACUUM**

Pfeiffer Vacuum Technology AG · Headquarters/Germany

Tel. +49-(0) 64 41-8 02-0 · Fax +49-(0) 64 41-8 02-2 02 · info@pfeiffer-vacuum.de · www.pfeiffer-vacuum.net